

Models CT2-2000 Fountain Installation Instructions

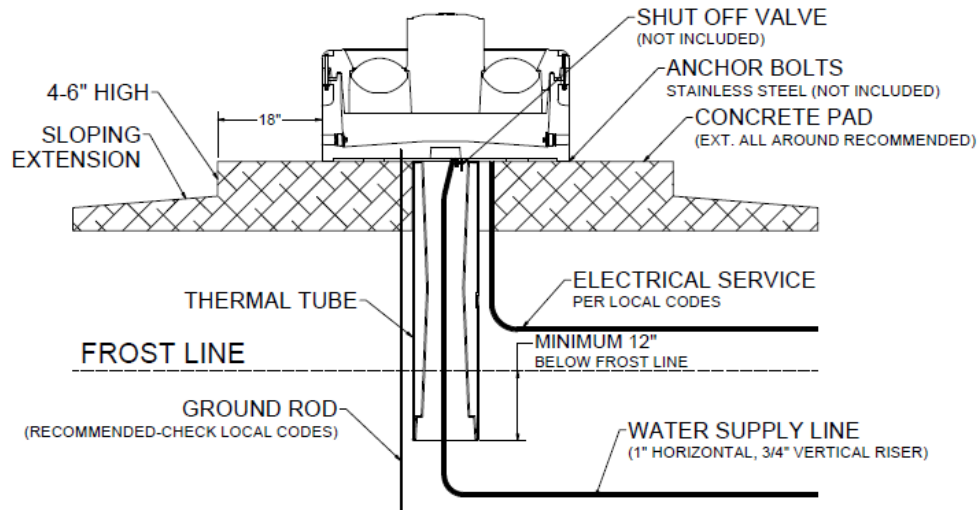

Thrifty King fountains are intended to be energy-free; however, several factors must be met for this to be the case:

- There must be at least 10 animals per drinking area that have the Thrifty King fountain as their only source of water.
- There must be a good seal against wind between the concrete platform and base of the unit.
- The water seal grooves between the base, and top of the unit, and between the top of the unit and the valve cover must be filled with liquid.
- The supply water temperature must be at least 42°F. (This may be an issue for rural or municipal water supplies.)

If these factors are not met, supplemental heat is recommended. Please see Supplemental Heat in the Special Situations section of this manual.

A. Location - Putting the fountain in a location that offers protection from the wind will enhance the performance of the fountain. Livestock will tend to gather in this protected area, enticing them to drink more. If possible, the side that supply line enters the fountain should be opposite of prevailing winter wind to give additional protection to the supply line.

B. Water Supply Line – Horizontal underground water line should be sized to account for pressure drop, relating to distance, and placed one foot below frost line. A one-inch supply pipe is recommended. A shut-off valve should be installed under the fountain to allow for easier servicing. For optimum serviceability, a stop and waste valve can be installed below frost level to drain water when unit is not in use. Vertical supply line must be centered in riser tube to provide an air space between the line and frozen ground outside of tube. Flush water supply line thoroughly before connection to fountain. Water supplies with foreign material such as sand, rust, etc. may require a filter to keep fountain valve working properly.

C. Riser Tube – Install a riser tube and extend it at least one foot below frost line or down to horizontal underground water line. For optimum water line protection, use the 12” diameter insulated Ritchie Thermal Tube, part numbers and sizes are shown to the right. Tube opening must be kept clear.

Ritchie Thermal Tube	
Part #	Description
18158	1' Top Section
16612	4' Top Section
16416	2' Extension

NOTE: *The supply line touching the riser tube is the most common cause of the supply line freezing. Do not surround the supply line with insulation, wood, or other foreign material. Any foreign material in the tube may cause frost to migrate to the supply line causing it to freeze.*

D. Electrical Connection (Optional) – Although Thrifty King fountains are designed to be electric free, there are circumstances where supplemental heat may be required. If electricity is available, it is a good management decision to run the electrical line for future use in the event your operation changes.

WARNING: ANY ELECTRICAL SERVICE MUST BE INSTALLED AND MAINTAINED BY A QUALIFIED ELECTRICIAN IN COMPLIANCE WITH LOCAL CODES.

E. Mounting Platform – A concrete platform should be provided for all fountains. It should be at least 4” thick and large enough to accommodate fountain. An additional 4” high step 18” out from each side of the unit will protect the unit from manure handling equipment, as well as discouraging animals from defecating in the fountain. Extending the platform provides animals a place to stand while drinking, consider the size of your animals when determining the dimensions of your platform. Slope the platform away from the fountain for drainage. A rough broom finish on the concrete surface provides better footing for animals.

F. Preparing the Bottom - Apply the foam weather stripping to the bottom of the unit, around the outside edge of the fountain.

G. Position Fountain - Connect hose to the top of the supply line, or the customer supplied shutoff valve at the top of the concrete. Place fountain on the concrete platform over the riser tube so the supply hose is centered in riser tube. Set the fountain on the concrete pad to inspect positioning of the installation. Once all connections are lined up, marking anchor bolt location can easily be done with a drill.

H. Hold-Downs – Thrifty King Fountains have mounting pockets molded into the base. Use of Ritchie stainless steel anchor bolts (not included) is recommended for concrete installations. Anchor bolts are available from any Ritchie authorized dealer, in packages of two, part # 16555. Once you have verified the positioning of the fountain, drill, install, and tighten down anchor bolts. Use the large washers provided to hold unit down. Tighten hold down anchors tight, but do not over tighten as this could damage the plastic feet.

I. Assemble Valve – Follow the steps to assemble the high-pressure valve included with your waterer.

1. Insert valve rubber into the valve rubber retainer.
2. Attach float arm to float as shown in diagram. The raised emboss on top of float should be orientated as shown.
3. Screw thumb screw into cam arm. To adjust water level, tighten thumb screw to lower, loosen thumb screw to raise.
4. Insert the valve rubber retainer into the valve body with the valve rubber up. Align the cam arm to the valve body and insert first pin.
5. Align the float arm and attached float to the cam arm and insert second pin.

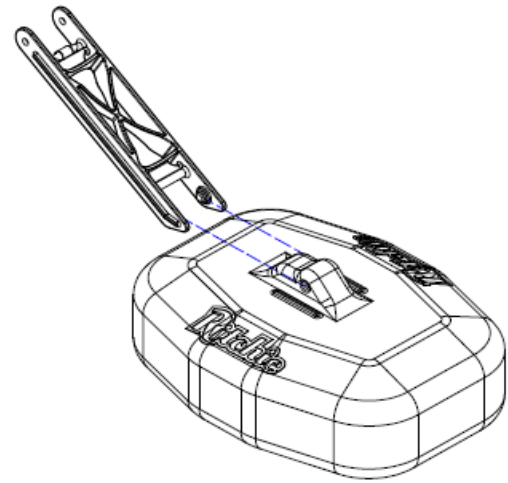

J. Valve mounting – After the fountain is in the proper place, place rubber washer, plastic washer, and nut on bulkhead, cut the hose to length and connect the valve bracket with hose clamp. Place the valve and bracket assembly in the slot provide in the wall of the valve chamber and tighten nut. Slide hose insulation up toward valve as far as possible and fasten with nylon tie wrap.

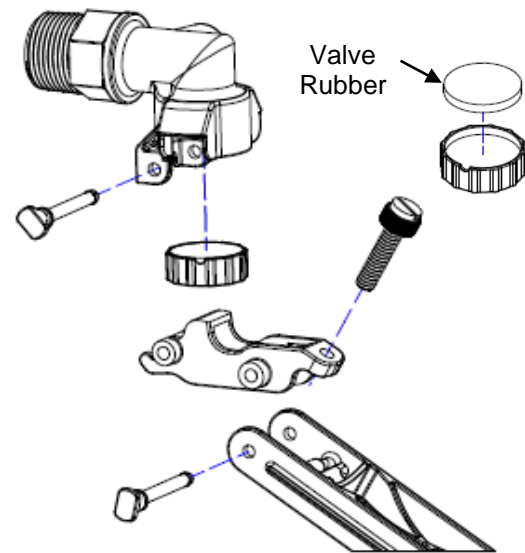

K. Seal the Base - After the unit is completely installed, apply a bead of caulking around the base of the fountain to ensure no wind enters through the base of the unit.

NOTE: *Sealing the bottom of the unit from cold air is an important aspect of the unit's thermal performance.*

L. Drain Plug – The pre-assembled drain plugs should go on the lower holes on the sidewall of the unit. **Install drain plugs from inside of trough.** Tighten plastic wing nut to secure plug.

NOTE: *To drain the unit, you can push the plug from outside of the unit into the center of the unit, instead of reaching into the water to pull the plug out. After the fountain drains, then reach in to retrieve the plug and install it from the inside.*

M. Install Unit Top - Set the elliptical closures inside the unit base. Place the top of the fountain on the base and position the elliptical closures to sit in the drink wells. (Final placement will require the closures to float in the well.) Thrifty King fountains employ the water seal design. Fill the water seal groove with liquid to seal against air infiltration before assembling. Do not use foam seal in this area. Bolt the unit top down to the base using the bolts, washers, and nuts provided.

Tip: *You may use vegetable oil to fill the water seal groove or coat the inside of the groove with baking pan coating spray before filling with water to make the cover easier to remove and reinstall during freezing weather. For areas with high evaporation, using vegetable oil may be necessary.*

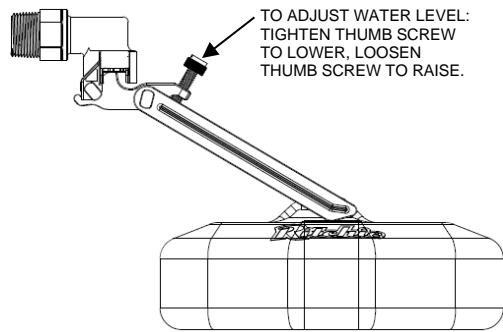

N. Float Adjustment - Turn on the water supply, check for and correct any leaks. Adjust valve thumb screw to adjust water level. To lower the water level, manually adjust float with hand and then set thumb screw. The water level should be adjusted to leave a gap of 1/2" between the elliptical closure and the rim of the water well. If the closures rest against the rim, they are more likely to freeze together.

O. Water Seal Drain – Install the small drain plug into the drain hole in the water seal groove around the valve chamber seal. This plug may be removed during non-freezing periods to allow the water seal groove to drain.

P. Install Valve Chamber Cover - Fill the water seal groove with liquid to seal against air infiltration before assembling. Fasten the valve chamber cover with the hardware provided. Note: Serial number or date code is found on underneath side of top red valve cover.

Q. Cleaning Your Fountain – To clean your watering fountain you will need a good stiff bristled brush. Remove the cover then brush the water seal groove to remove any build-up then brush the tank. Remove the drain plug that is in the drink area to drain out the water and debris. You can shut off the water with the shut-off valve located under the unit or by holding the float in the up position. After the water and debris has drained reinstall the plug and let the tank refill. Now is a good time to readjust the float if needed. Reinstall cover and you are done.

Special Situations

Supplemental Heat

Immersion heaters are available for cold weather climates. The 250-watt heater part #16311 should be adequate for Thrifty Kings. Additionally, self-regulating heat cables are available to protect supply hose from freezing, 120V, part #16276. Immersion heaters should be placed flat on the bottom of the valve chamber. Ensure that the placement of the heater and its power cable do not interfere with the motion of the float assembly.

NOTE: *Supply line heat cables should wrap around the valve and follow the supply line down into the riser tube. You may use nylon ties to anchor the heat cable to the supply line.*

Non-Siphoning

The Ritchie Thrifty King fountains meet Grade-A dairy non-siphoning guidelines.

Ritchie Valves

The Thrifty King CT2-2000 comes standard with our 3/4" yellow high-pressure valve that is rated up to 110 psi. If water pressure is very high and valve does not shut off consistently, a pressure-reducing valve (Ritchie #18649) may be needed.

Trouble Shooting

Problem	Solution
Elliptical Closure Sticking	Make sure the closure floats at least 1/2” below the rim of the water well, so water does not get trapped above the closure and freeze the closure to the rim of the well.
Water Freezing in the Valve, Supply Line, or Drink Area	Make sure the fountain is sealed from wind between the concrete platform and bottom of unit
	Make sure both water seal grooves are filled with liquid
	Make sure there are at least 10 animals drinking from only this fountain. (No other source of water available.)
	Make sure incoming water is at least 42°F
	Make sure supply line is properly insulated: <ul style="list-style-type: none"> ▪ Foam rubber insulation around supply line ▪ Riser tube with supply line centered, and air space between riser tube and supply line. Ritchie Thermal Tubes are recommended. ▪ Horizontal supply line is at least 1 foot below frost line
	If the above conditions cannot be met, use supplemental heat.
Low Water Flow	Check that valve inlet is not plugged or supply hose is not kinked
	Check system pressure from supply hose by installing a tee and pressure gauge in front of the valve to check pressure drop when valve is open. A severe pressure drop indicates a restriction or undersized supply system.
	Check that shut off valves are fully open
Valve Won't Stop Dripping	Check float adjustment. Ensure float moves freely
	Take valve apart and check for sand or scale in valve rubber.
	Turn valve rubber over and re-assemble. See below
	Check for excessive water system pressure.
	Change to higher pressure valve.

Thrifty King CT2-2000

Part # 16299

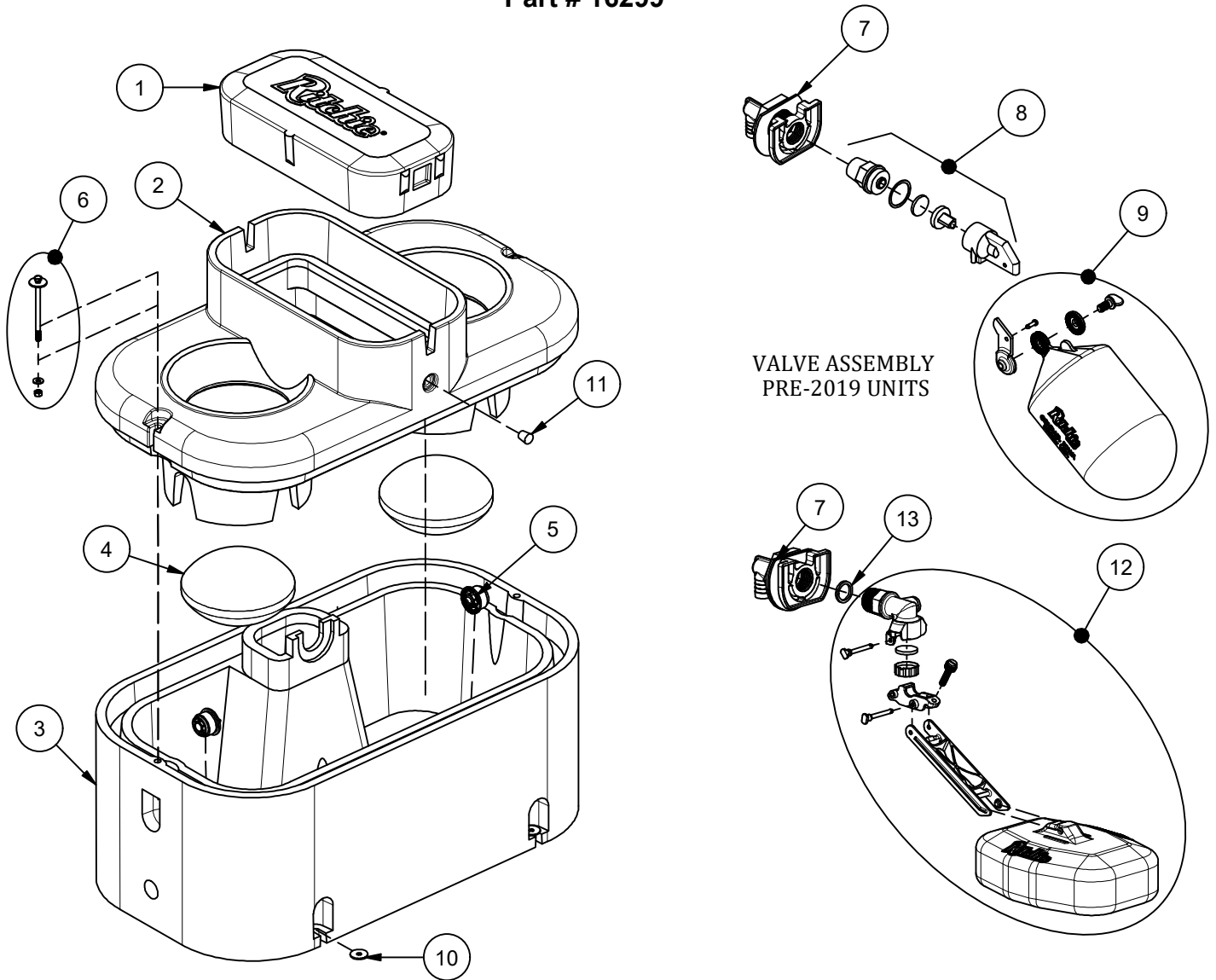

VALVE ASSEMBLY
PRE-2019 UNITS

Item	Part #	Description	Qty	Item	Part #	Description	Qty
1	16893	Thrifty King CT2 Cover	1	10	18318	Bolt Down Washer (4/pkg)	1 pkg
2	16894	Thrifty King CT2 Top	1	11	18633	Plug #3 - Water Channel	1 pkg
3	16895	Thrifty King CT2 Base	1	12	18832	HP 3/4" Valve Assembly	1
4	16305	Elliptical Closures	2	13	18475	O-Ring Valve Seal Pkg (4/pkg)	1
5	18849	Ritchie 2" Plug pkg	2 pkgs	NS	14866	Seal Foam 10' Roll	2
6	16538	Top Bolt, Wshr, & Nut (2/pkg)	1 pkg	NS	14859	Pipe Insulation	1
7	18838	VLV HP Brkt Assy pkg	1 pkg	NS	15931	Hose Clamp SS (5/pkg)	1 pkg
8	15377	Green Valve 3/4" Male pkg	1 pkg	NS	18614	Adapter 3/4" x 5/8" HB	1 pkg
9	18314	Float with Hardware pkg	1 pkg	NS	18340	TK CT2 Accessory pkg	1 pkg
	18313	Hardware for Float pkg	1 pkg	NS	16646	Opt. Ribbed Elliptical Closures	2



RITCHIE INDUSTRIES, INC. LIMITED WARRANTY

Ritchie Industries, Inc., hereinafter referred to as Ritchie Industries, gives a LIMITED WARRANTY for the period of time(s) stated herein, subject to certain limitations, on your new watering system against defects in material or workmanship when properly installed, set up, operated, and maintained in accordance with the instructions and recommendations set forth by Ritchie Industries, including in the Installation Instructions. **The warranty excludes labor and shipping charges.**

The warranty is transferable to the next purchaser of the watering system prior to expiration of the warranty period, but any such transfer will not extend the original warranty term. Proof of purchase must be submitted with any warranty claim, and all warranty claims shall be processed through an Authorized Ritchie Dealer or Distributor.

Ritchie Industries' liability for any defects in material or workmanship with respect to accepted goods shall be limited to repairing the goods or replacing them as Ritchie Industries shall elect. Parts used in warranty repairs will be warranted for the balance of the water system's warranty period, with all parts replaced under warranty becoming the property of Ritchie Industries.

The limited warranty periods begin upon delivery of the watering system to the original purchaser. Upon delivery of the goods, purchaser assumes all liability, including but not limited to all personal injury and property damage, resulting from the handling, possession, or use of the goods.

WARRANTY COVERAGE AND LIMITATIONS

Limitations of Warranties and Remedies

Ritchie Industries' watering systems are designed and manufactured to provide years of reliable use when installed and operated consistent with Ritchie Industries' instructions and recommendations. However, the potential for improper installation, modifications and misuse of the goods exists. Therefore, the limited warranty provided shall be as follows:

This limited warranty shall not apply to any appearance items and shall not apply to any product which has been subject to misuse, abuse, abnormal service or handling, negligence, or accident, nor to any product that is installed and/or used contrary to Ritchie Industries' installation instructions and instructions for use. The limited warranty shall also not apply to any product whose exterior has been damaged or otherwise defaced, that has been repaired, altered, or modified by anyone, other than Ritchie Industries, in a way so as in Ritchie Industries' judgment it adversely affects the product's operation, performance, durability, or intended use, nor to any product where removal of parts, modification(s) or use of parts or accessories not manufactured or approved by Ritchie Industries has caused damage.

Coverage and Warranty Periods

Unit Type	Coverage and Warranty Period
Poly Units	Base, top, and ball closures. Ten-year limited warranty: 100% for first five years, then declining 20% per year for remainder of the 10-year period.
Stainless Steel Units	Stainless trough and stainless valve chamber frame. Ten-year limited warranty, plus ten years of corrosion coverage, at 100% for entire 10-year period.
Component Parts	One-year limited warranty on all component parts, such as floats, valves, and heating elements.

Exclusions of Liability

EXCEPT AS OTHERWISE EXPRESSLY STATED HEREIN, RITCHIE INDUSTRIES MAKES NO OTHER WARRANTY OR REPRESENTATION OF ANY KIND, EXPRESSED OR IMPLIED. **THE IMPLIED WARRANTY OF MERCHANTABILITY AND FITNESS FOR A PARTICULAR PURPOSE ARE EXCLUDED FROM THIS LIMITED WARRANTY.** TO THE EXTENT THEY CANNOT BE DISCLAIMED, THE IMPLIED WARRANTIES ARE LIMITED IN DURATION TO THE LIFE OF THE EXPRESS WARRANTY. **THIS LIMITED WARRANTY EXCLUDES INCIDENTAL, CONSEQUENTIAL, AND SPECIAL DAMAGES. THIS EXCLUSION OF CONSEQUENTIAL, INCIDENTAL, AND SPECIAL DAMAGES IS INDEPENDENT FROM AND SHALL SURVIVE ANY FINDING THAT THE EXCLUSIVE REMEDY FAILED OF ITS ESSENTIAL PURPOSE.** THE REMEDIES SET FORTH IN THIS LIMITED WARRANTY ARE THE ONLY REMEDIES AVAILABLE TO ANY PERSON UNDER THIS WARRANTY. SOME STATES/PROVINCES DO NOT ALLOW FOR THE DISCLAIMERS, LIMITATIONS, AND EXCLUSIONS IDENTIFIED ABOVE AND, AS A RESULT, THEY MAY NOT APPLY TO YOU.

No agent, employee or representative of Ritchie Industries, and no Ritchie Industries Dealer/Distributor, is authorized to bind Ritchie Industries to any representation or warranty regarding the goods except as specifically included in this limited warranty.

Installation Instructions for



Thrifty King CT2-2000 Fountains

Congratulations, you have just purchased the finest watering fountain on the market. This unit is built to give you excellent service when properly installed and maintained. Please follow instructions carefully. Read and understand all instructions before installing.

Ritchie Industries, Inc.
800-747-0222
www.ritchiefount.com



TK CT2 ACC PKG

18340

847987083400

A rectangular box containing a barcode on the left, the large number '18340' in the center, the text 'TK CT2 ACC PKG' below it, another barcode on the right, and the number '847987083400' at the bottom right.